



CON. FÊMEA RETO PARA PAINEL PINO MACHO CRIMPAGEM RGC-58

CÓDIGO: TF- 32

SÉRIE: TNC 50 OHMS

NORMA: IEC 169- 17

PESO DO CONECTOR: 13,66g

Rosca 7/16" x 28 Fios

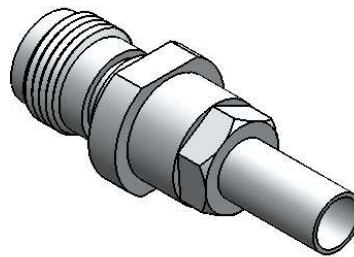
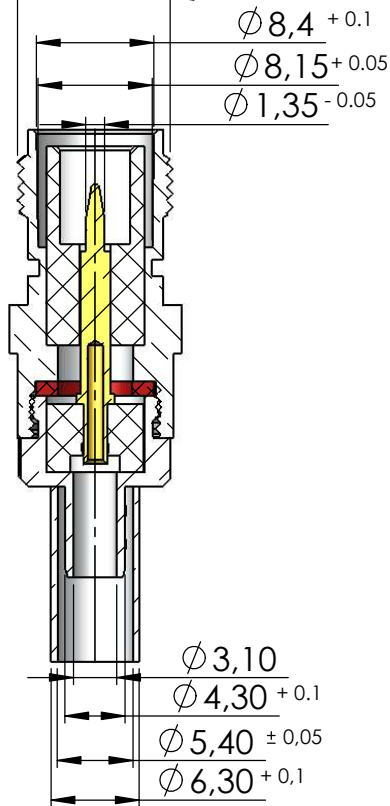

Instruções montagem do cabo no conector

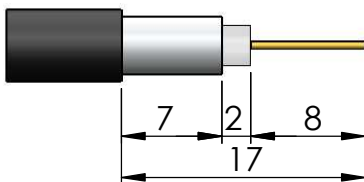

1) Corte do cabo.

Crimpar ou soldar



3) Introduzir o condutor do cabo no pino, e crimpar ou soldar. Colocando a malha sobre a parte recartilhada do redutor.



2) Introduzir a bucha no cabo.

Crimpar

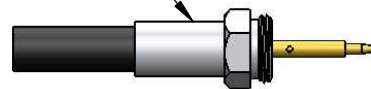

4) Colocar a bucha sobre a malha até encostar no redutor e crimpá-la.

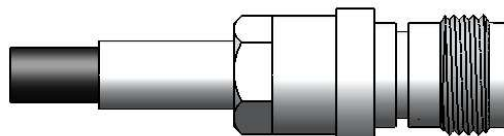

5) Introduzir o pino com o redutor no corpo de conector.