



CON. MACHO ANGULAR PRENSA CABO RGC-8,RGC-11, RG e RGC-213

CÓDIGO: 5045

SÉRIE: DIN 7/16

NORMA: IEC 169-4

PESO DO CONECTOR: 182,41 g

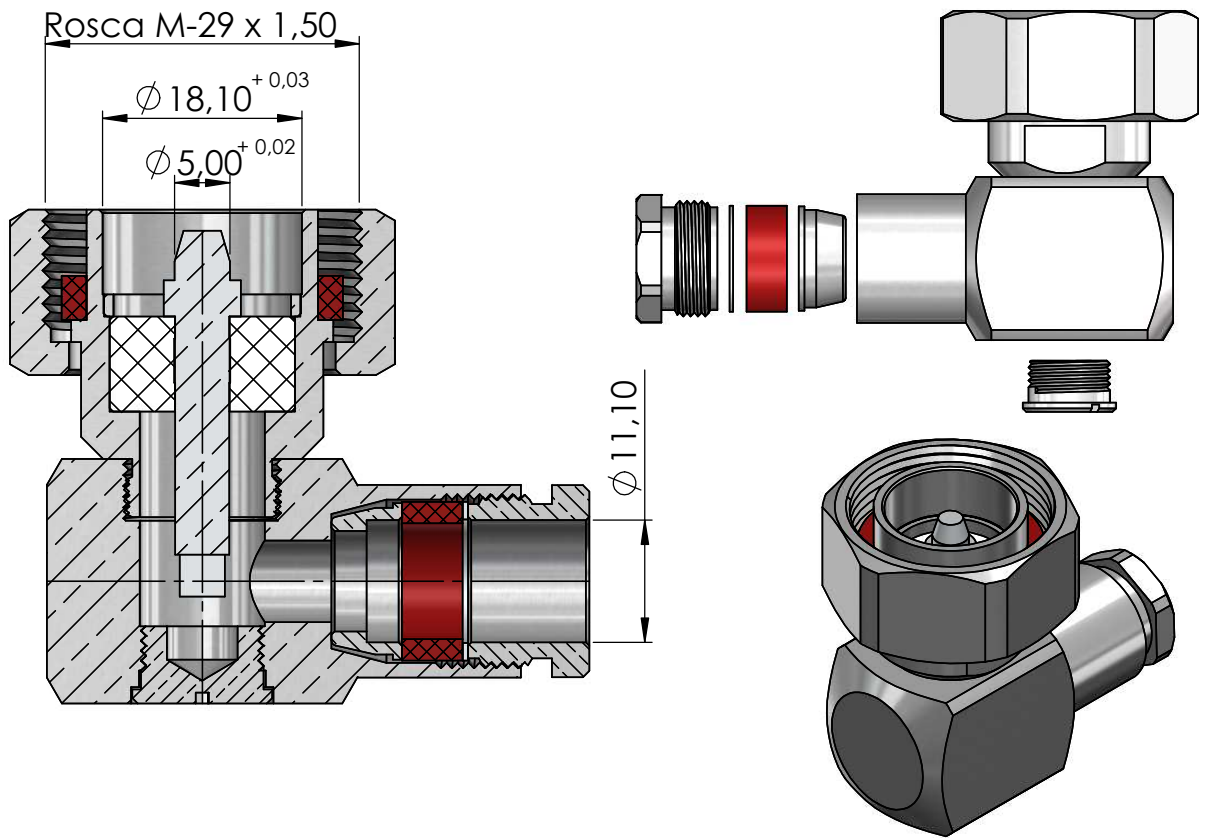

Instruções montagem do cabo no conector

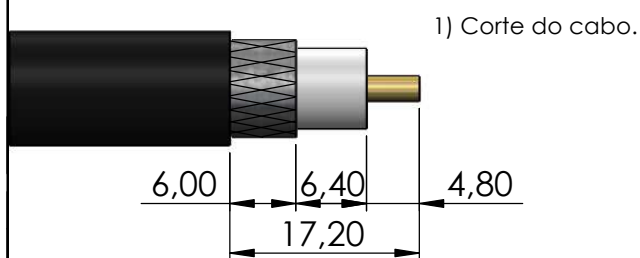

2) Fechar a malha e introduzir os componentes na seguinte ordem: redutor, arruela, anel de vedação e bucha até encostar na capa de vinil.

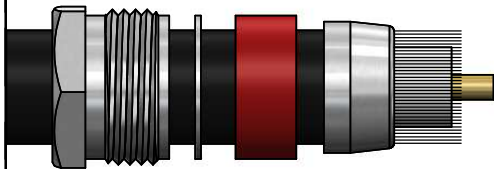

4) Empure o conector no cabo até que o condutor do cabo fique sobre o fresado do contato do conector. Soldar o condutor.

