



CONECTOR MACHO RETO PRENSA CABO RG-223

CÓDIGO: 5054

SÉRIE: DIN 7/16

NORMA: IEC 169- 4

PESO DO CONECTOR: 108,08g

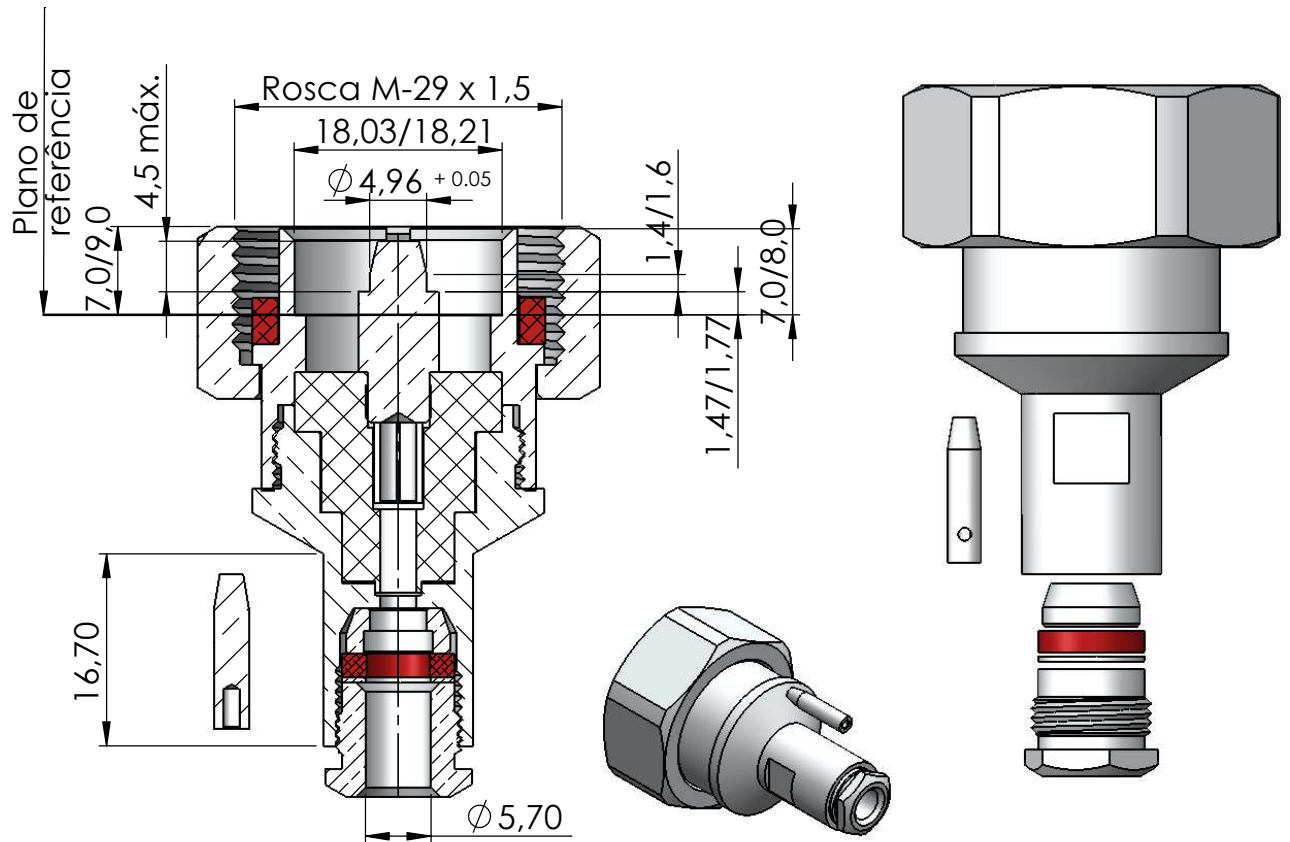

Instruções montagem do cabo no conector

