



CONECTOR MACHO RETO CRIMPAGEM RG/RGC-213 e LMR-400

CÓDIGO: CM-46

SÉRIE: N 50 OHMS

NORMA: IEC 169-16

PESO DO CONECTOR: 25,46g

Rosca 5/8" x 24 fios

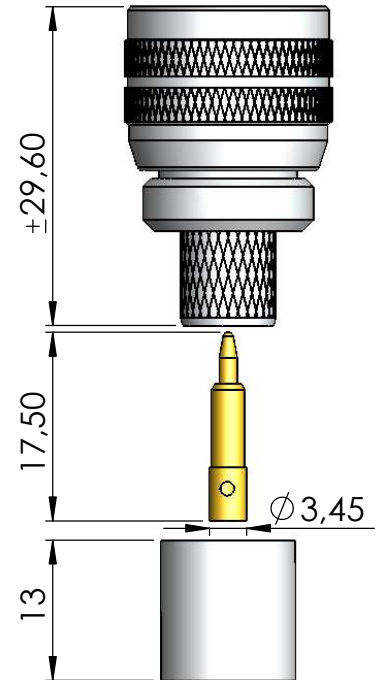
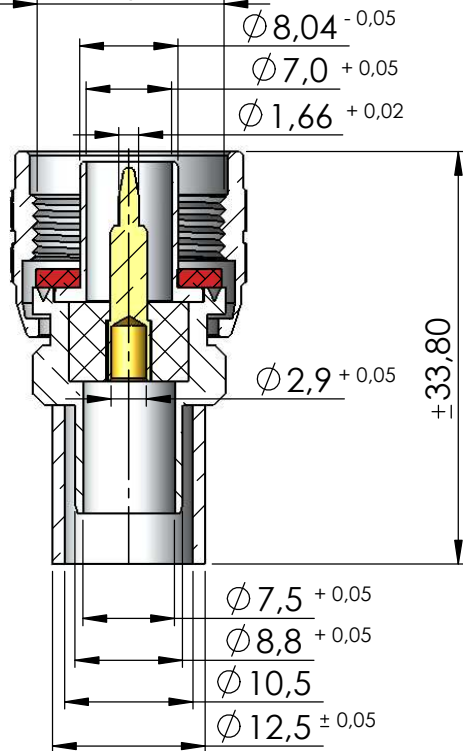

Instruções montagem do cabo no conector

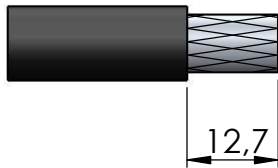

1) Cortar a capa de vinil expondo a malha 12,7mm.

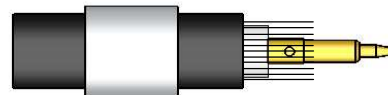

4) Fechar a malha e introduzir a malha e o cabo.

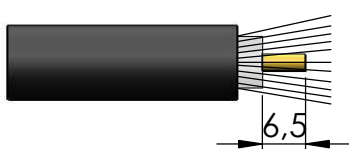

2) Abrir a malha e cortar o dielétrico expondo o condutor central 6,5mm.

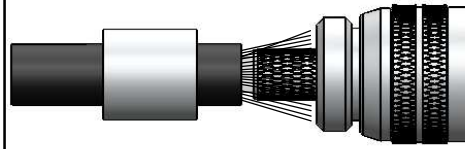

5) Introduzir o cabo no conector colocando a malha sobre a parte recartilhada do conector.

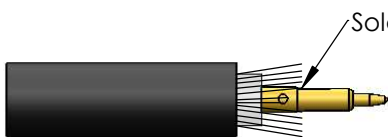

3) Soldar o condutor do cabo no pino.

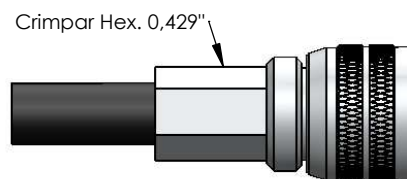

6) Colocar a bucha sobre a malha até encostar no conector e crimpá-la.