



CONECTOR FÊMEA RETO PARA PAINEL CRIMPAGEM RG/RGC-58

CÓDIGO: 3273

SÉRIE: SMA 50 OHMS

NORMA: IEC 169-15

PESO DO CONECTOR: 5,05g

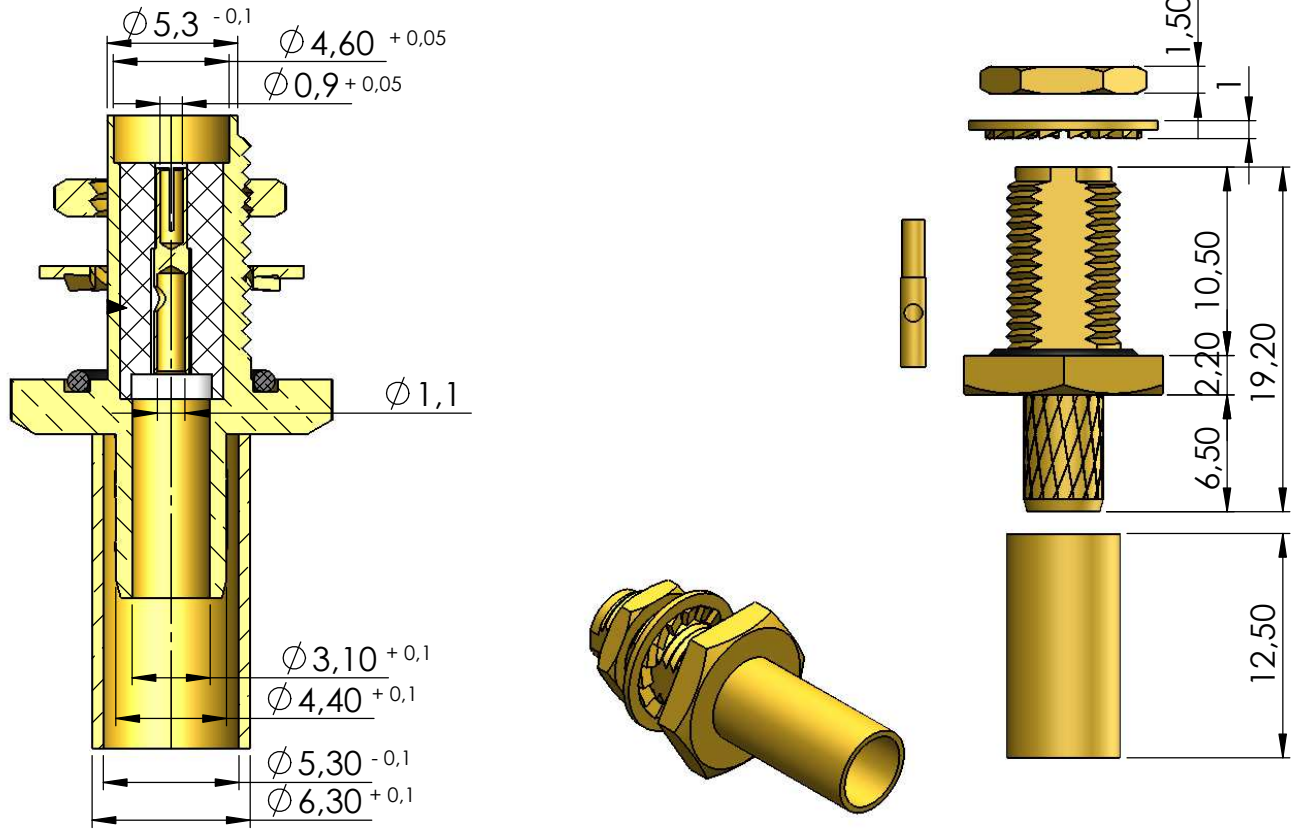

Instruções montagem do cabo no conector

