



CONECTOR FÊMEA RETO PINO MACHO P/ PAINEL CRIMPAGEM RG-174

CÓDIGO: 3202

SÉRIE: SMA 50 OHMS

NORMA: IEC 169-15

PESO DO CONECTOR: 3,81g

Rosca 1/4" x 36 Fios

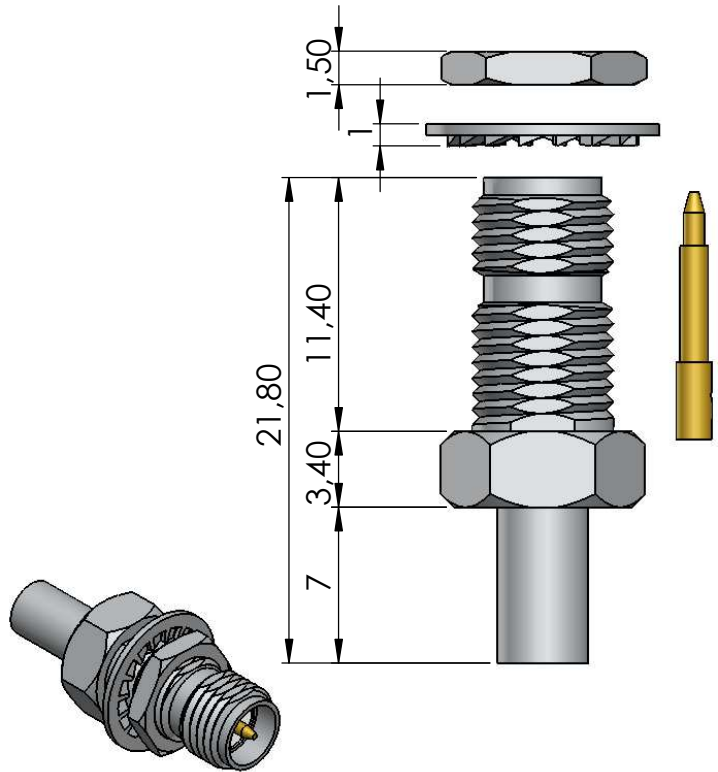
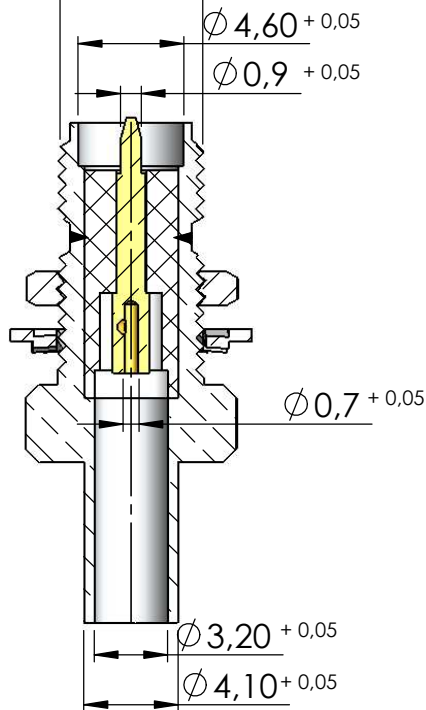

Instruções montagem do cabo no conector

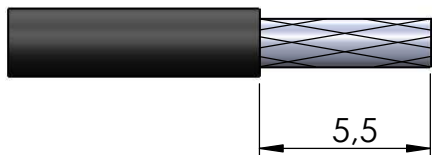

1) Corte do cabo.

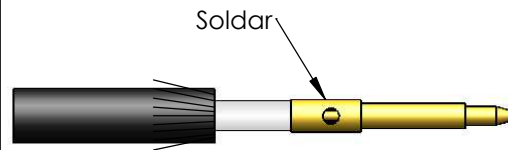

3) Soldar o condutor central no pino.

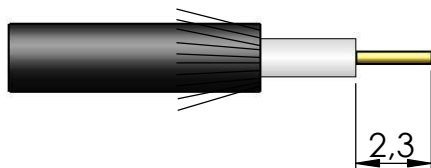

2) Dobrar a malha para trás e cortar dielétrico.

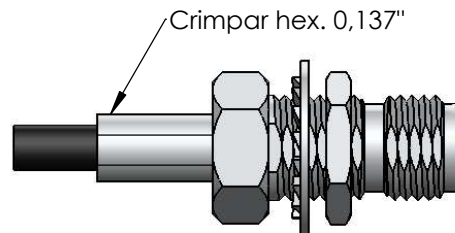

4) Introduzir o pino soldado no conector até encostar no isolante e crimpar.