



CON. FÊMEA RETO PARA PAINEL CRIMPAGEM CABO RG/RGC-58

CÓDIGO: 3168

SÉRIE: SMA 50 OHMS

NORMA: IEC- 169 15

PESO DO CONECTOR: 4,93g

Rosca 1/4" x 36 Fios

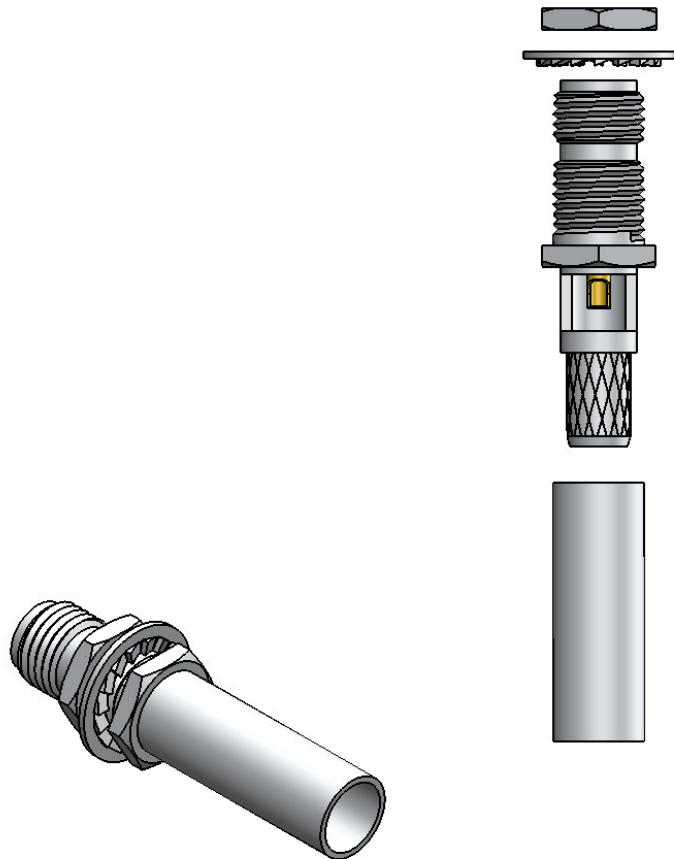
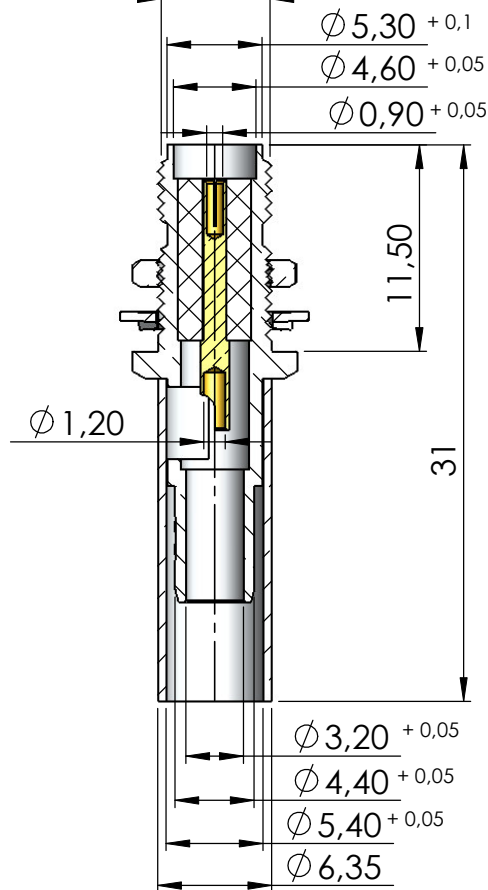

Instruções montagem do cabo no conector

