



CONECTOR MACHO RETO CRIMPAGEM CABO RG/RGC-58

CÓDIGO: TM- 70

SÉRIE: TNC 50 OHMS

NORMA: IEC 169-17

PESO DO CONECTOR: 11,84g

Rosca 7/16" x 28 Fios

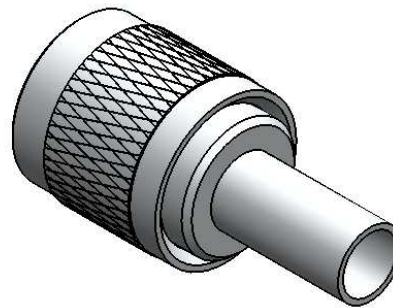
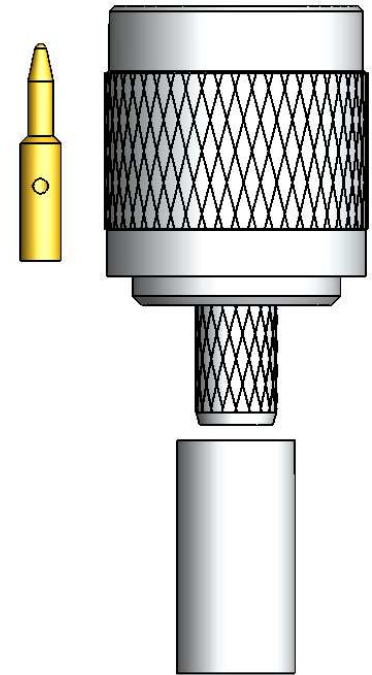
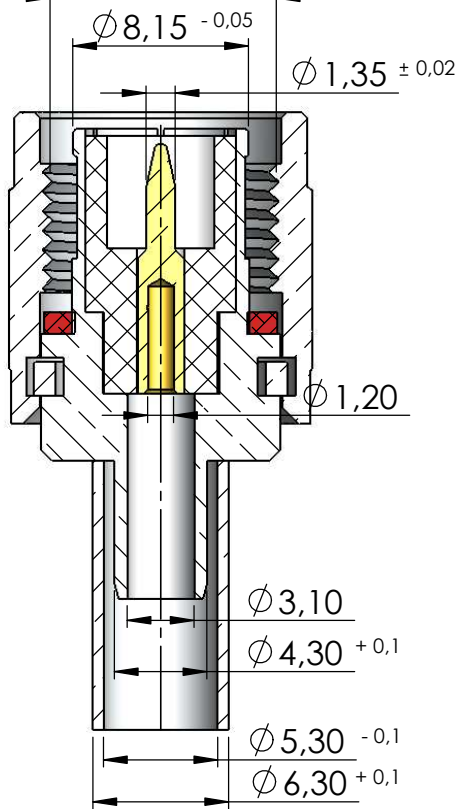

Instruções montagem do cabo no conector

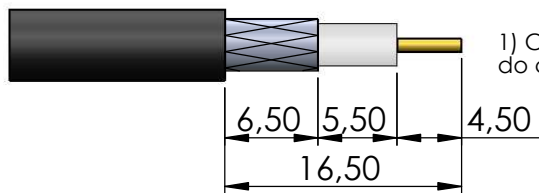

1) Corte do cabo.

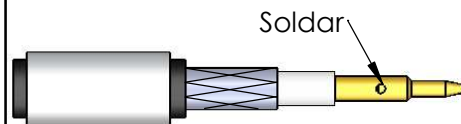

Soldar

3) Introduzir o pino no condutor do cabo e soldar.

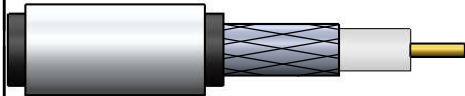

2) Introduzir a bucha no cabo.

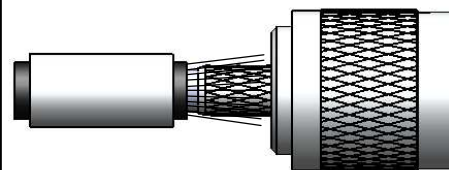

4) Introduzir o cabo no corpo colocando a malha sobre a parte recartilhada do conector.

Crimpar hex. 0,213"

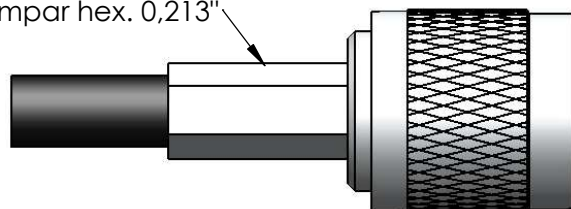

5) Colocar a bucha sobre a malha e crimpá-la.