



CONECTOR MACHO ANGULAR CRIMPAGEM RG e RGC-58

CÓDIGO: LM-30

SÉRIE: BNC 50 OHMS

NORMA: IEC 169-8

PESO DO CONECTOR: 22,43g

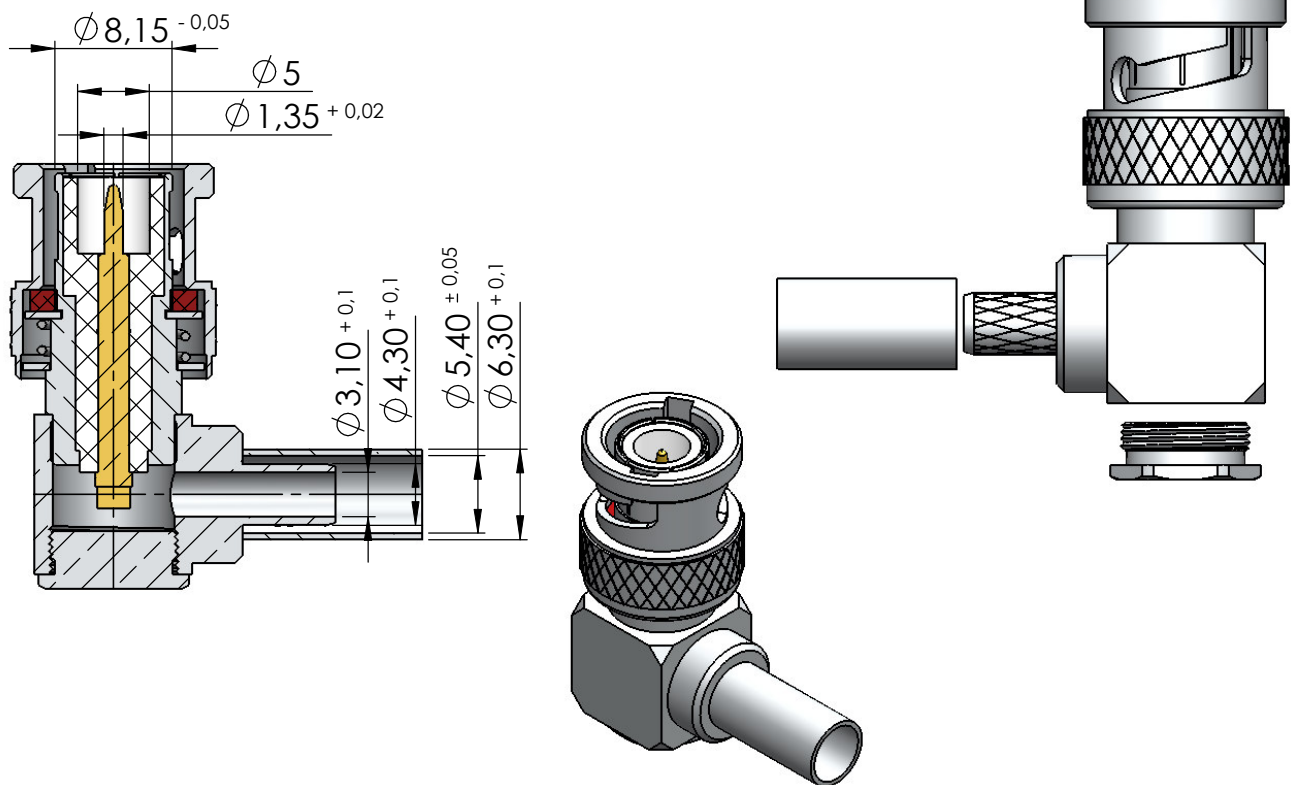

Instruções montagem do cabo no conector

