



CONECTOR MACHO ANGULAR CRIMPAGEM CABO 3C2W

CÓDIGO: 13037

SÉRIE: 1.0/2.3

NORMA: DIN 47297

PESO DO CONECTOR: 9,73g

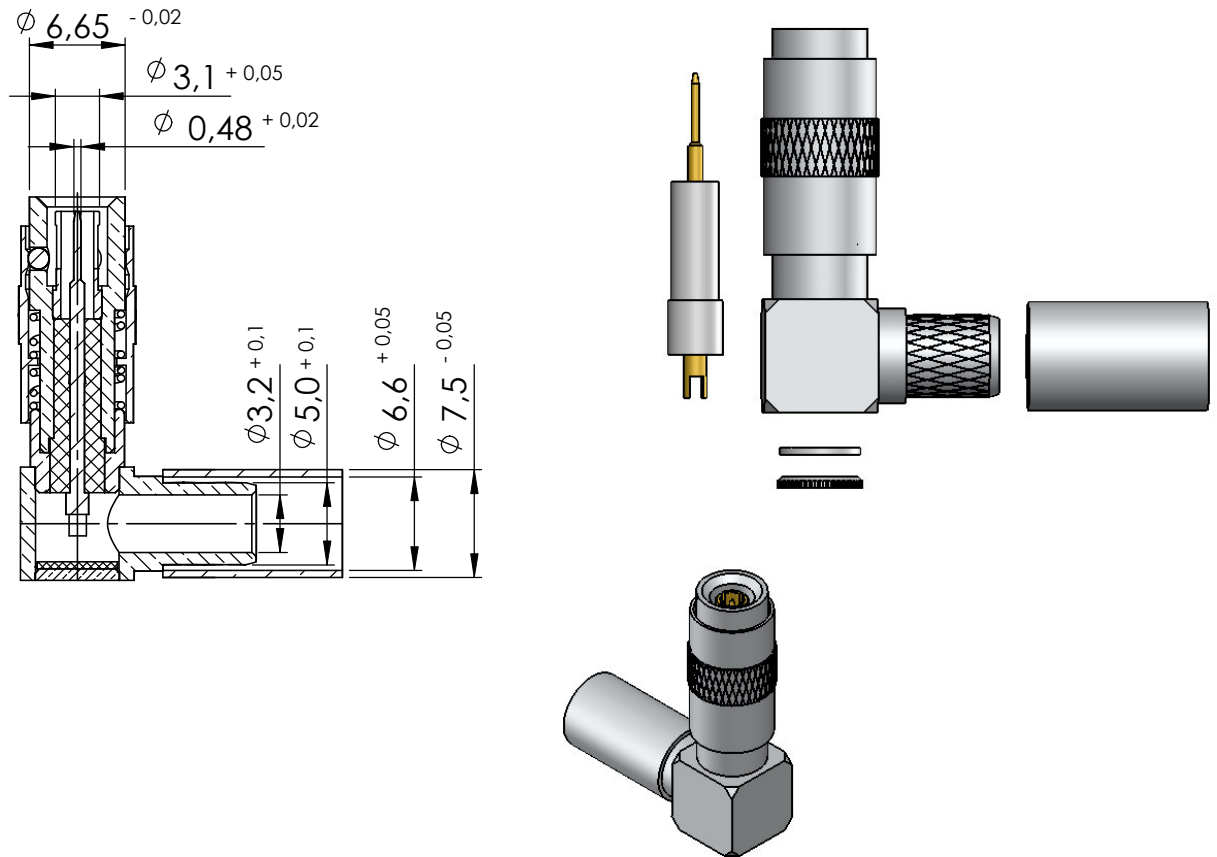

Instruções de montagem do cabo no conector

