



CONECTOR MACHO ANGULAR CRIMPAGEM RG-223

CÓDIGO: TM- 59

SÉRIE: TNC 50 OHMS

NORMA: IEC 169-17

PESO DO CONECTOR: 23,7g

Rosca 7/16" x 28 Fios

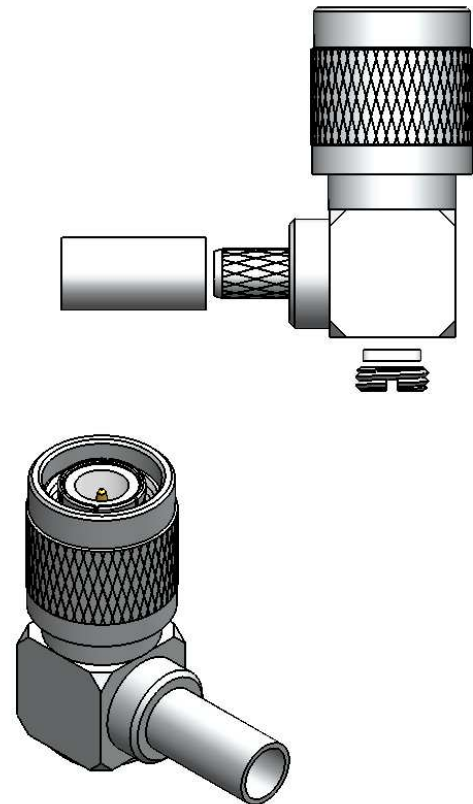
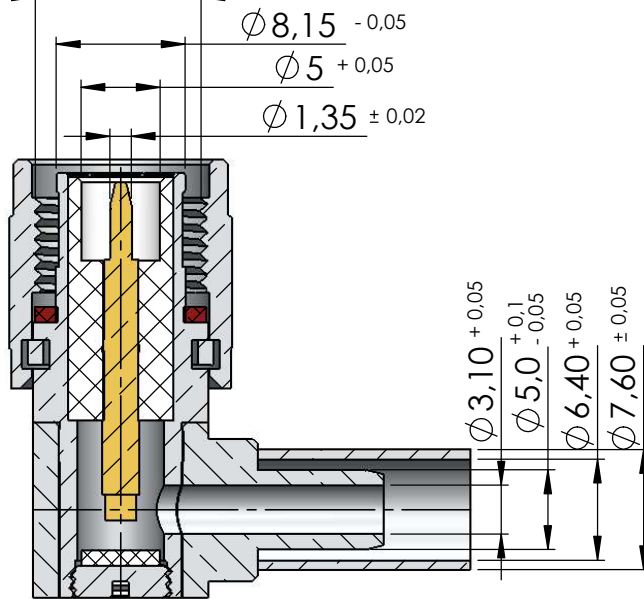

Instruções montagem do cabo no conector

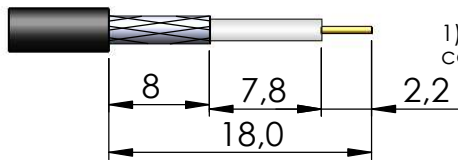

1) Corte do cabo.

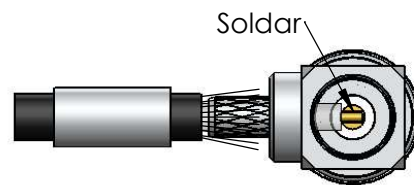

3) Introduzir o cabo no conector até encostar o condutor do cabo no fresado do conector e soldar.

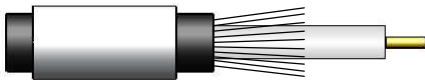

2) Introduzir a bucha no cabo abrir a malha.

Crimpar hex. 0,255"

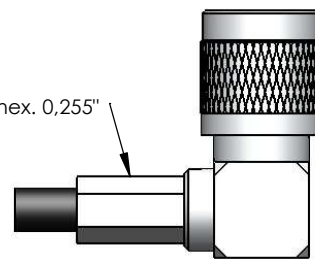

3) Empure a bucha de crimp. sobre a malha e crimpar.

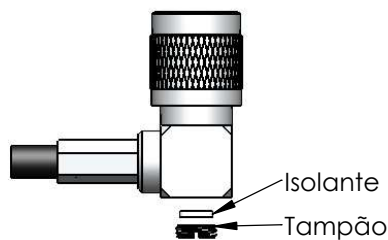

5) Colocar isolante e rosquear tampão